

A Story of Units

Pleasanton
UNIFIED SCHOOL DISTRICT

Mathematics Curriculum



Grade 5 • MODULE 5

Addition and Multiplication with Volume and Area

PROBLEM SETS

Video tutorials: <http://embarc.online>

Info for parents: <http://bit.ly/pusdmath>

Version 3



Table of Contents

GRADE 5 • MODULE 5

Addition and Multiplication with Volume and Area

Module Overview	2
Topic A: Concepts of Volume	11
Topic B: Volume and the Operations of Multiplication and Addition	52
Mid Module Assessment and Rubric	128
Topic C: Area of Rectangular Figures with Fractional Side Lengths	138
Topic D: Drawing, Analysis, and Classification of Two-Dimensional Shapes	219
End-of-Module Assessment and Rubric	311
Answer Key	321

NOTE: Student sheets should be printed at 100% scale to preserve the intended size of figures for accurate measurements. Adjust copier or printer settings to *actual size* and set page scaling to *none*.

Name _____

Date _____

1. Use your centimeter cubes to build the figures pictured below on centimeter grid paper. Find the total volume of each figure you built, and explain how you counted the cubic units. Be sure to include units.

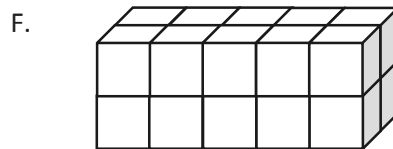
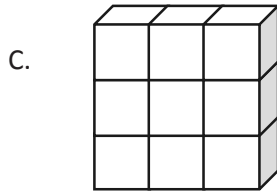
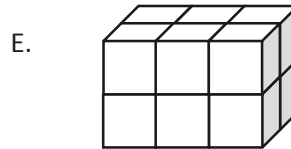
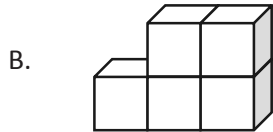
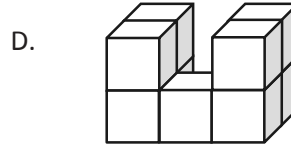
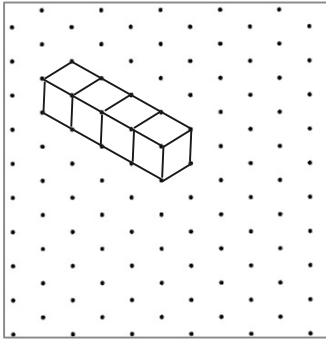

Figure	Volume	Explanation
A		
B		
C		
D		
E		
F		

2. Build 2 different structures with the following volumes using your unit cubes. Then, draw one of the figures on the dot paper. One example has been drawn for you.

a. 4 cubic units



b. 7 cubic units

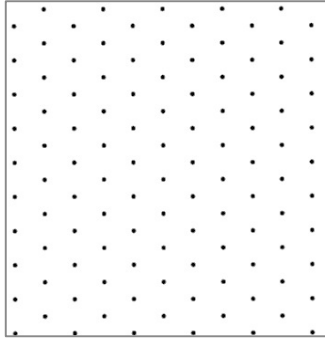

c. 8 cubic units

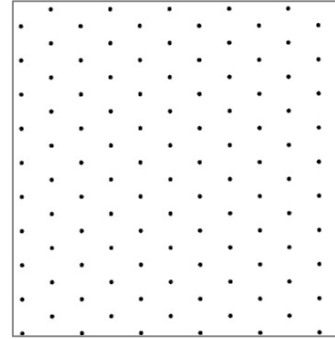

3. Joyce says that the figure below, made of 1 cm cubes, has a volume of 5 cubic centimeters.
- a. Explain her mistake.

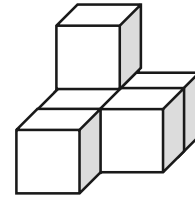

- b. Imagine if Joyce adds to the second layer so the cubes completely cover the first layer in the figure above. What would be the volume of the new structure? Explain how you know.

Name _____

Date _____

1. Shade the following figures on centimeter grid paper. Cut and fold each to make 3 open boxes, taping them so they hold their shapes. Pack each box with cubes. Write how many cubes fill each box.

a.

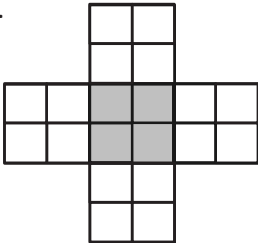

Number of cubes: _____

b.

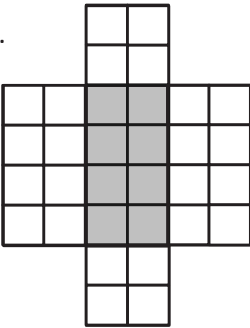

Number of cubes: _____

c.

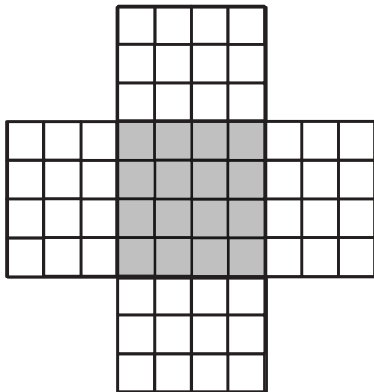

Number of cubes: _____

2. Predict how many centimeter cubes will fit in each box, and briefly explain your predictions. Use cubes to find the actual volume. (The figures are not drawn to scale.)

a.

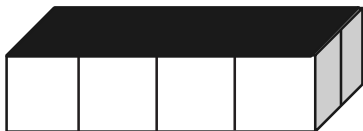

Prediction: _____

Actual: _____

b.

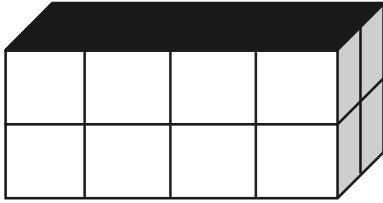

Prediction: _____

Actual: _____

c.

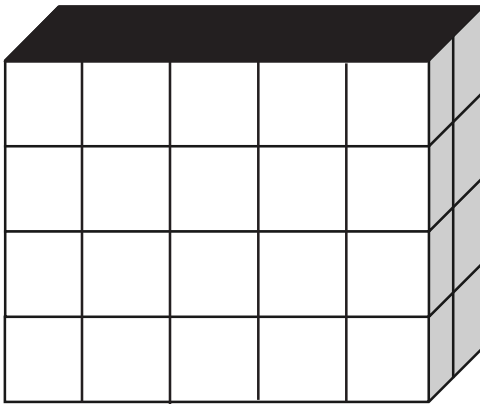

Prediction: _____

Actual: _____

3. Cut out the net in the template, and fold it into a cube. Predict the number of 1-centimeter cubes that would be required to fill it.

a. Prediction: _____

b. Explain your thought process as you made your prediction.

c. How many 1-centimeter cubes are used to fill the figure? Was your prediction accurate?

Name _____

Date _____

1. Use the prisms to find the volume.

- Build the rectangular prism pictured below to the left with your cubes, if necessary.
- Decompose it into layers in three different ways, and show your thinking on the blank prisms.
- Complete the missing information in the table.

a.

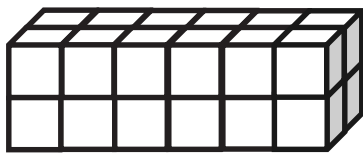

Number of Layers	Number of Cubes in Each Layer	Volume of the Prism
		cubic cm
		cubic cm
		cubic cm

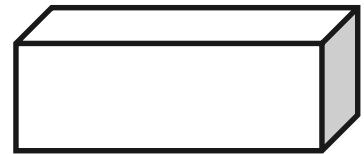
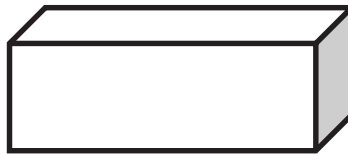
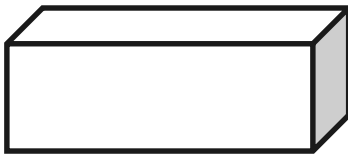

b.

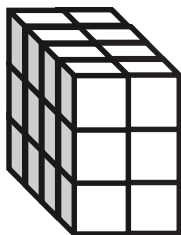

Number of Layers	Number of Cubes in Each Layer	Volume of the Prism
		cubic cm
		cubic cm
		cubic cm

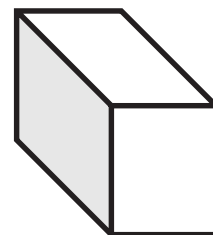
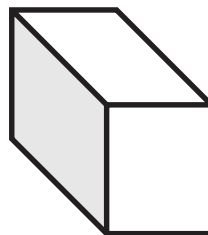
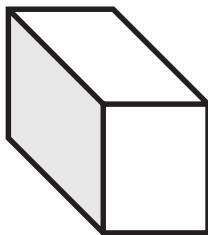

2. Josh and Jonah were finding the volume of the prism to the right. The boys agree that 4 layers can be added together to find the volume. Josh says that he can see on the end of the prism that each layer will have 16 cubes in it. Jonah says that each layer has 24 cubes in it. Who is right? Explain how you know using words, numbers, and/or pictures.

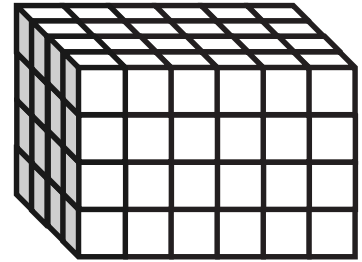

3. Marcos makes a prism 1 inch by 5 inches by 5 inches. He then decides to create layers equal to his first one. Fill in the chart below, and explain how you know the volume of each new prism.

Number of Layers	Volume	Explanation
2		
4		
7		

4. Imagine the rectangular prism below is 6 meters long, 4 meters tall, and 2 meters wide. Draw horizontal lines to show how the prism could be decomposed into layers that are 1 meter in height.

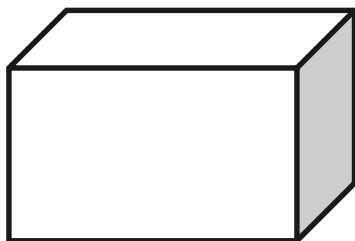

It has _____ layers from bottom to top.

Each horizontal layer contains _____ cubic meters.

The volume of this prism is _____.

Name _____

Date _____

Use these rectangular prisms to record the layers that you count.

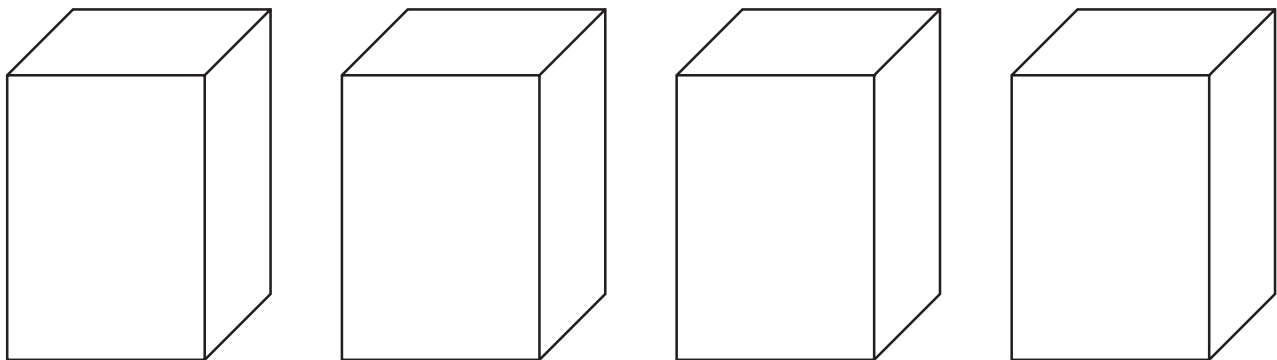
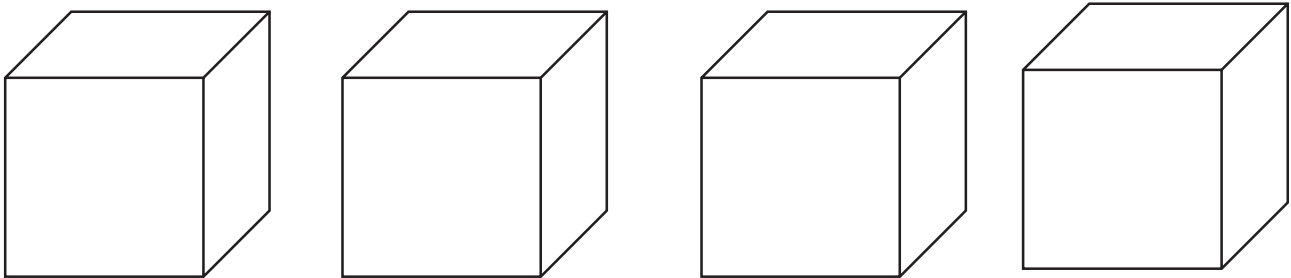
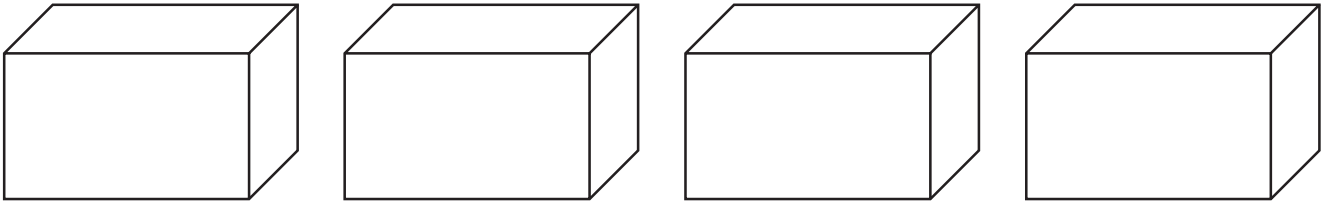
_____
rectangular prism recording sheet

Name _____

Date _____

1. Each rectangular prism is built from centimeter cubes. State the dimensions, and find the volume.

a.

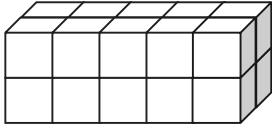

Length: _____ cm

Width: _____ cm

Height: _____ cm

Volume: _____ cm^3

b.

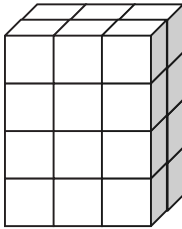

Length: _____ cm

Width: _____ cm

Height: _____ cm

Volume: _____ cm^3

c.

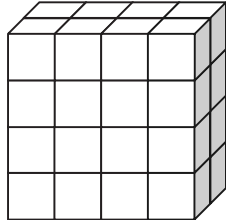

Length: _____ cm

Width: _____ cm

Height: _____ cm

Volume: _____ cm^3

d.

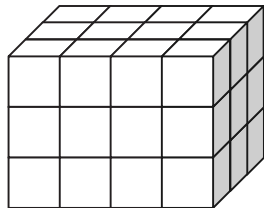

Length: _____ cm

Width: _____ cm

Height: _____ cm

Volume: _____ cm^3

2. Write a multiplication sentence that you could use to calculate the volume for each rectangular prism in Problem 1. Include the units in your sentences.

a. _____

b. _____

c. _____

d. _____

3. Calculate the volume of each rectangular prism. Include the units in your number sentences.

a.

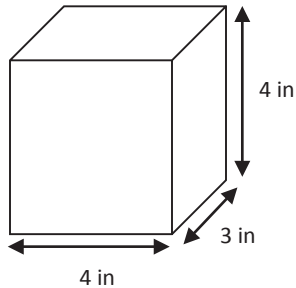

$V =$ _____

b.

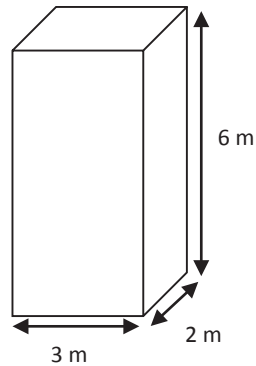

$V =$ _____

4. Tyron is constructing a box in the shape of a rectangular prism to store his baseball cards. It has a length of 10 centimeters, a width of 7 centimeters, and a height of 8 centimeters. What is the volume of the box?

5. Aaron says more information is needed to find the volume of the prisms. Explain why Aaron is mistaken, and calculate the volume of the prisms.

a.

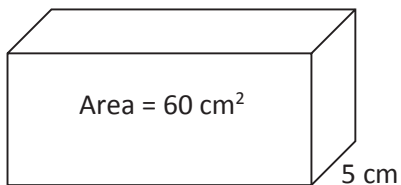

b.

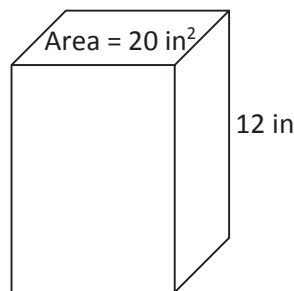

Name _____

Date _____

Use these rectangular prisms to record the layers that you count.

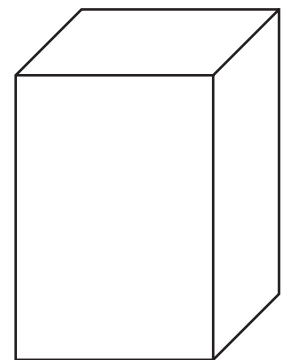
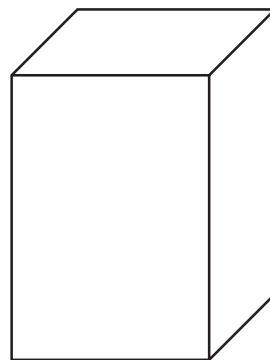
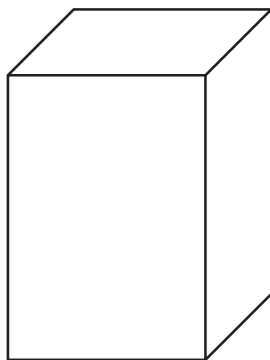
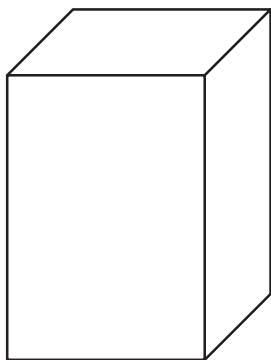
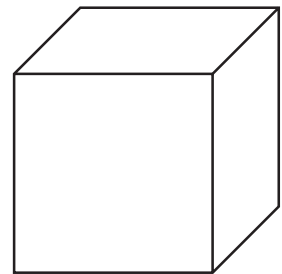
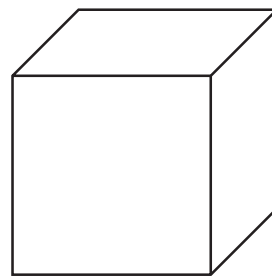
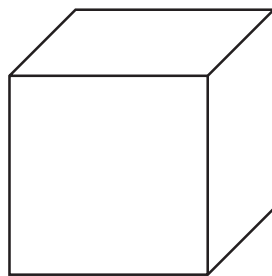
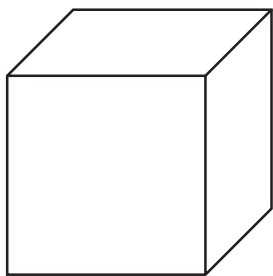
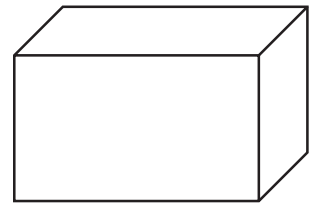
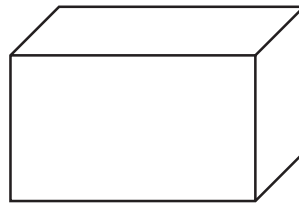
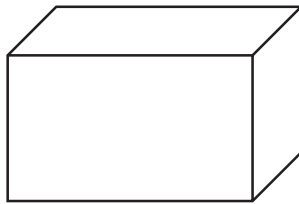
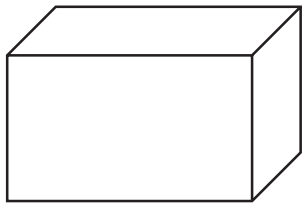

rectangular prism recording sheet (from Lesson 3)

Name _____

Date _____

1. Determine the volume of two boxes on the table using cubes, and then confirm by measuring and multiplying.

Box Number	Number of Cubes Packed	Measurements			Volume
		Length	Width	Height	

2. Using the same boxes from Problem 1, record the amount of liquid that your box can hold.

Box Number	Liquid the Box Can Hold
	mL
	mL

3. Shade to show the water in the beaker.

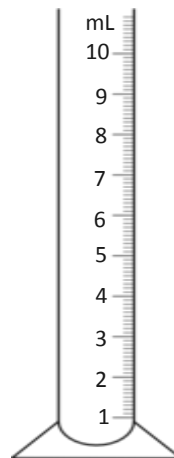
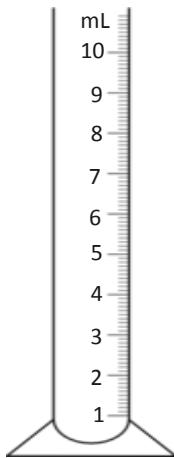
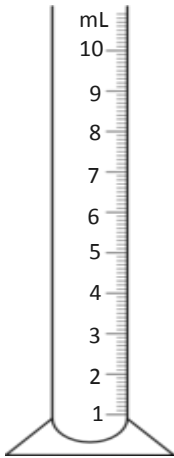

At first:

_____ mL

After 1 mL water added:

_____ mL

After 1 cm cube added:

_____ mL

4. What conclusion can you draw about 1 cubic centimeter and 1 mL?

5. The tank, shaped like a rectangular prism, is filled to the top with water.

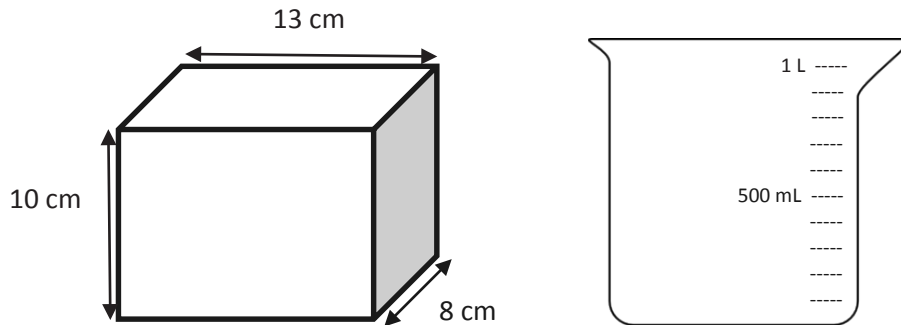

Will the graduated cylinder hold all the water in the tank? If yes, how much more will the beaker hold? If no, how much more will the tank hold than the beaker? Explain how you know.

6. A rectangular fish tank measures 26 cm by 20 cm by 18 cm. The tank is filled with water to a depth of 15 cm.

a. What is the volume of the water in mL?

b. How many liters is that?

c. How many more mL of water will be needed to fill the tank to the top? Explain how you know.

7. A rectangular container is 25 cm long and 20 cm wide. If it holds 1 liter of water when full, what is its height?

Name _____

Date _____

1. Find the total volume of the figures, and record your solution strategy.

a.

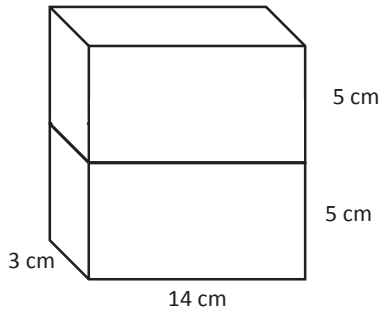

Volume: _____

Solution Strategy:

b.

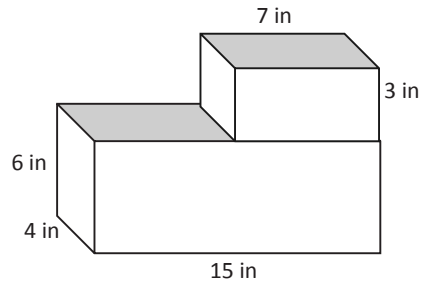

Volume: _____

Solution Strategy:

c.

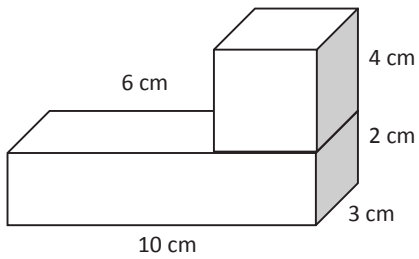

Volume: _____

Solution Strategy:

d.

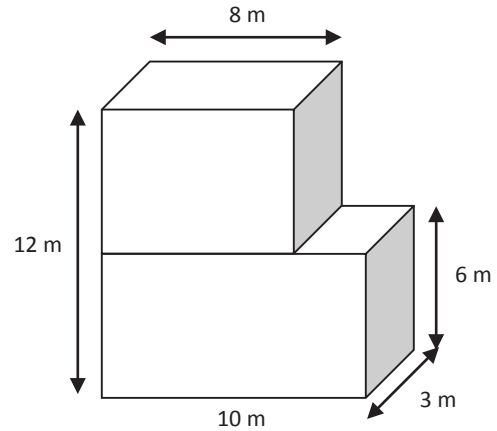

Volume: _____

Solution Strategy:

2. A sculpture (pictured below) is made of two sizes of rectangular prisms. One size measures 13 in by 8 in by 2 in. The other size measures 9 in by 8 in by 18 in. What is the total volume of the sculpture?

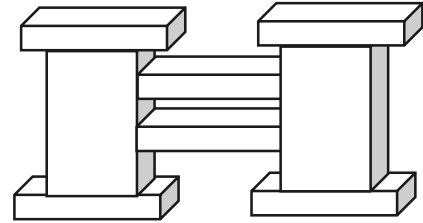

3. The combined volume of two identical cubes is 128 cubic centimeters. What is the side length of each cube?
4. A rectangular tank with a base area of 24 cm^2 is filled with water and oil to a depth of 9 cm. The oil and water separate into two layers when the oil rises to the top. If the thickness of the oil layer is 4 cm, what is the volume of the water?



5. Two rectangular prisms have a combined volume of 432 cubic feet. Prism A has half the volume of Prism B.
- What is the volume of Prism A? Prism B?
 - If Prism A has a base area of 24 ft^2 , what is the height of Prism A?
 - If Prism B's base is $\frac{2}{3}$ the area of Prism A's base, what is the height of Prism B?

Name _____

Date _____

Geoffrey builds rectangular planters.

1. Geoffrey's first planter is 8 feet long and 2 feet wide. The container is filled with soil to a height of 3 feet in the planter. What is the volume of soil in the planter? Explain your work using a diagram.

2. Geoffrey wants to grow some tomatoes in four large planters. He wants each planter to have a volume of 320 cubic feet, but he wants them all to be different. Show four different ways Geoffrey can make these planters, and draw diagrams with the planters' measurements on them.

Planter A	Planter B
Planter C	Planter D

3. Geoffrey wants to make one planter that extends from the ground to just below his back window. The window starts 3 feet off the ground. If he wants the planter to hold 36 cubic feet of soil, name one way he could build the planter so it is not taller than 3 feet. Explain how you know.
4. After all of this gardening work, Geoffrey decides he needs a new shed to replace the old one. His current shed is a rectangular prism that measures 6 feet long by 5 feet wide by 8 feet high. He realizes he needs a shed with 480 cubic feet of storage.
- Will he achieve his goal if he doubles each dimension? Why or why not?
 - If he wants to keep the height the same, what could the other dimensions be for him to get the volume he wants?
 - If he uses the dimensions in part (b), what could be the area of the new shed's floor?

Name _____

Date _____

Using the box patterns, construct a sculpture containing at least 5, but not more than 7, rectangular prisms that meets the following requirements in the table below.

1.	My sculpture has 5 to 7 rectangular prisms.	Number of prisms: _____
2.	Each prism is labeled with a letter, dimensions, and volume.	
	Prism A _____ by _____ by _____	Volume = _____
	Prism B _____ by _____ by _____	Volume = _____
	Prism C _____ by _____ by _____	Volume = _____
	Prism D _____ by _____ by _____	Volume = _____
	Prism E _____ by _____ by _____	Volume = _____
	Prism ____ _____ by _____ by _____	Volume = _____
	Prism ____ _____ by _____ by _____	Volume = _____
3.	Prism D has $\frac{1}{2}$ the volume of Prism ____.	Prism D Volume = _____ Prism ____ Volume = _____
4.	Prism E has $\frac{1}{3}$ the volume of Prism ____.	Prism E Volume = _____ Prism ____ Volume = _____
5.	The total volume of all the prisms is 1,000 cubic centimeters or less.	Total volume: _____ Show calculations:

Name _____

Date _____

I reviewed project number _____.

Use the rubric below to evaluate your friend's project. Ask questions and measure the parts to determine whether your friend has all the required elements. Respond to the prompt in italics in the third column. The final column can be used to write something you find interesting about that element if you like.

Space is provided beneath the rubric for your calculations.

	Requirement	Element Present? (✓)	Specifics of Element	Notes
1.	The sculpture has 5 to 7 prisms.		<i># of prisms:</i>	
2.	All prisms are labeled with a letter.		<i>Write letters used:</i>	
3.	All prisms have correct dimensions with units written on the top.		<i>List any prisms with incorrect dimensions or units:</i>	
4.	All prisms have correct volume with units written on the top.		<i>List any prism with incorrect dimensions or units:</i>	
5.	Prism D has $\frac{1}{2}$ the volume of another prism.		<i>Record on next page:</i>	
6.	Prism E has $\frac{1}{3}$ the volume of another prism.		<i>Record on next page:</i>	
7.	The total volume of all the parts together is 1,000 cubic units or less.		<i>Total volume:</i>	

Calculations:

8. Measure the dimensions of each prism. Calculate the volume of each prism and the total volume. Record that information in the table below. If your measurements or volume differ from those listed on the project, put a star by the prism label in the table below, and record on the rubric.

Prism	Dimensions	Volume
A	_____ by _____ by _____	
B	_____ by _____ by _____	
C	_____ by _____ by _____	
D	_____ by _____ by _____	
E	_____ by _____ by _____	
	_____ by _____ by _____	
	_____ by _____ by _____	

9. Prism D's volume is $\frac{1}{2}$ that of Prism _____.
Show calculations below.

10. Prism E's volume is $\frac{1}{3}$ that of Prism _____.
Show calculations below.

11. Total volume of sculpture: _____.
Show calculations below.

Name _____

Date _____

Sketch the rectangles and your tiling. Write the dimensions and the units you counted in the blanks. Then, use multiplication to confirm the area. Show your work. We will do Rectangles A and B together.

1. **Rectangle A:**

Rectangle A is

_____ units long _____ units wide

Area = _____ units²2. **Rectangle B:**

Rectangle B is

_____ units long _____ units wide

Area = _____ units²3. **Rectangle C:**

Rectangle C is

_____ units long _____ units wide

Area = _____ units²4. **Rectangle D:**

Rectangle D is

_____ units long _____ units wide

Area = _____ units²5. **Rectangle E:**

Rectangle E is

_____ units long _____ units wide

Area = _____ units²

6. The rectangle to the right is composed of squares that measure $2\frac{1}{4}$ inches on each side. What is its area in square inches? Explain your thinking using pictures and numbers.

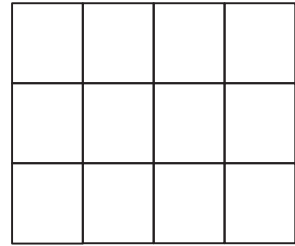

7. A rectangle has a perimeter of $35\frac{1}{2}$ feet. If the length is 12 feet, what is the area of the rectangle?

Name _____

Date _____

Draw the rectangle and your tiling.

Write the dimensions and the units you counted in the blanks.

Then, use multiplication to confirm the area. Show your work.

1. **Rectangle A:**2. **Rectangle B:**

Rectangle A is

_____ units long _____ units wide

Area = _____ units²

Rectangle B is

_____ units long _____ units wide

Area = _____ units²3. **Rectangle C:**4. **Rectangle D:**

Rectangle C is

_____ units long _____ units wide

Area = _____ units²

Rectangle D is

_____ units long _____ units wide

Area = _____ units²

5. Colleen and Caroline each built a rectangle out of square tiles placed in 3 rows of 5. Colleen used tiles that measured $1\frac{2}{3}$ cm in length. Caroline used tiles that measured $3\frac{1}{3}$ cm in length.
- a. Draw the girls' rectangles, and label the lengths and widths of each.
- b. What are the areas of the rectangles in square centimeters?
- c. Compare the areas of the rectangles.
6. A square has a perimeter of 51 inches. What is the area of the square?

Name _____

Date _____

1. Measure each rectangle to the nearest $\frac{1}{4}$ inch with your ruler, and label the dimensions. Use the area model to find each area.

a.

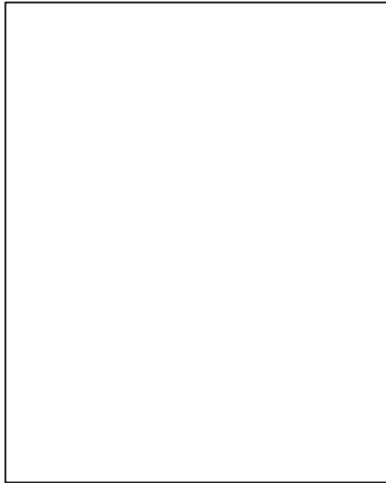

b.

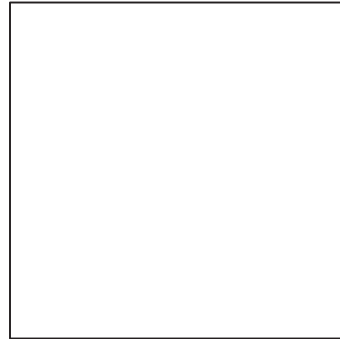

c.



d.

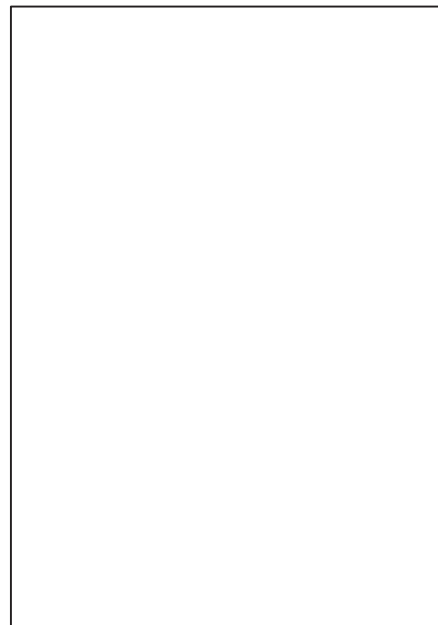

e.

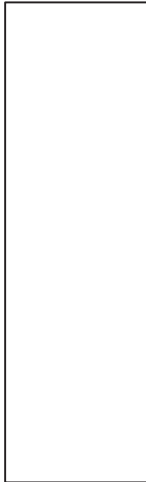

f.



2. Find the area of rectangles with the following dimensions. Explain your thinking using the area model.

a. $1 \text{ ft} \times 1\frac{1}{2} \text{ ft}$

b. $1\frac{1}{2} \text{ yd} \times 1\frac{1}{2} \text{ yd}$

c. $2\frac{1}{2} \text{ yd} \times 1\frac{3}{16} \text{ yd}$

3. Hanley is putting carpet in her house. She wants to carpet her living room, which measures $15 \text{ ft} \times 12\frac{1}{3} \text{ ft}$. She also wants to carpet her dining room, which is $10\frac{1}{4} \text{ ft} \times 10\frac{1}{3} \text{ ft}$. How many square feet of carpet will she need to cover both rooms?

4. Fred cut a $9\frac{3}{4}$ -inch square of construction paper for an art project. He cut a square from the edge of the big rectangle whose sides measured $3\frac{1}{4}$ inches. (See the picture below.)

a. What is the area of the smaller square that Fred cut out?

b. What is the area of the remaining paper?

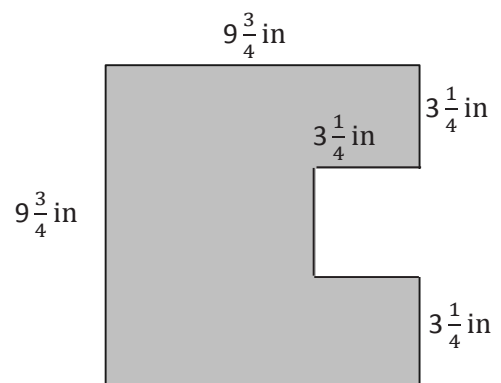

Name _____

Date _____

1. Find the area of the following rectangles. Draw an area model if it helps you.

a. $\frac{5}{4} \text{ km} \times \frac{12}{5} \text{ km}$

b. $16\frac{1}{2} \text{ m} \times 4\frac{1}{5} \text{ m}$

c. $4\frac{1}{3} \text{ yd} \times 5\frac{2}{3} \text{ yd}$

d. $\frac{7}{8} \text{ mi} \times 4\frac{1}{3} \text{ mi}$

2. Julie is cutting rectangles out of fabric to make a quilt. If the rectangles are $2\frac{3}{5}$ inches wide and $3\frac{2}{3}$ inches long, what is the area of four such rectangles?

3. Mr. Howard's pool is connected to his pool house by a sidewalk as shown. He wants to buy sod for the lawn, shown in gray. How much sod does he need to buy?

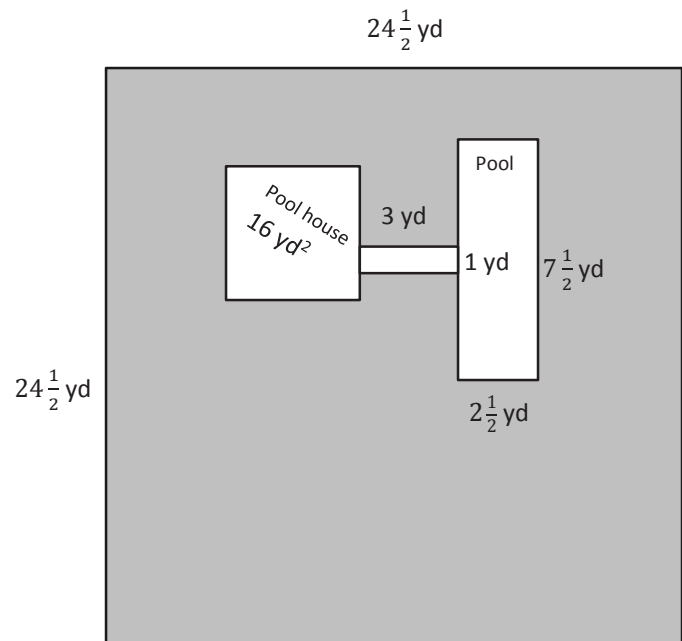

Name _____

Date _____

1. George decided to paint a wall with two windows. Both windows are $3\frac{1}{2}$ -ft by $4\frac{1}{2}$ -ft rectangles. Find the area the paint needs to cover.

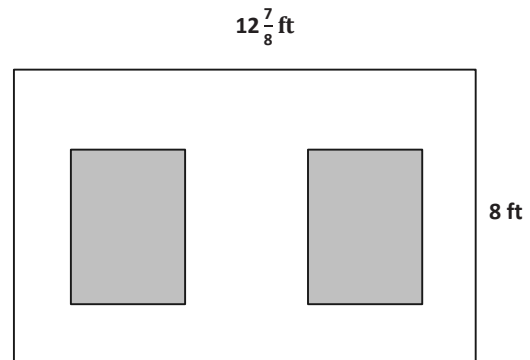

2. Joe uses square tiles, some of which he cuts in half, to make the figure below. If each square tile has a side length of $2\frac{1}{2}$ inches, what is the total area of the figure?

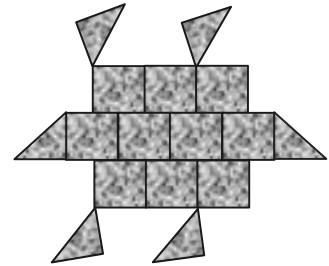

3. All-In-One Carpets is installing carpeting in three rooms. How many square feet of carpet are needed to carpet all three rooms?

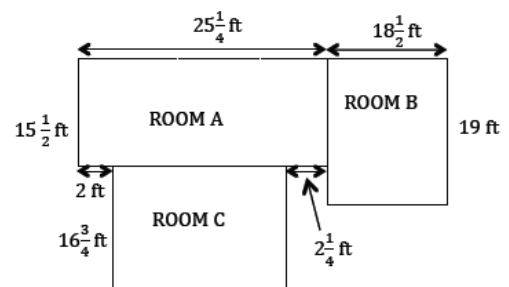

4. Mr. Johnson needs to buy sod for his front lawn.
- a. If the lawn measures $36\frac{2}{3}$ ft by $45\frac{1}{6}$ ft, how many square feet of sod will he need?
- b. If sod is only sold in whole square feet, how much will Mr. Johnson have to pay?

Sod Prices

Area	Price per Square Foot
First 1,000 sq ft	\$0.27
Next 500 sq ft	\$0.22
Additional square feet	\$0.19

5. Jennifer's class decides to make a quilt. Each of the 24 students will make a quilt square that is 8 inches on each side. When they sew the quilt together, every edge of each quilt square will lose $\frac{3}{4}$ of an inch.
- a. Draw one way the squares could be arranged to make a rectangular quilt. Then, find the perimeter of your arrangement.
- b. Find the area of the quilt.

Name _____

Date _____

1. The length of a flowerbed is 4 times as long as its width. If the width is $\frac{3}{8}$ meter, what is the area?

2. Mrs. Johnson grows herbs in square plots. Her basil plot measures $\frac{5}{8}$ yd on each side.

a. Find the total area of the basil plot.

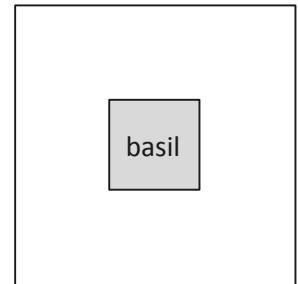

b. Mrs. Johnson puts a fence around the basil. If the fence is 2 ft from the edge of the garden on each side, what is the perimeter of the fence in feet?

- c. What is the total area, in square feet, that the fence encloses?
3. Janet bought 5 yards of fabric $2\frac{1}{4}$ -feet wide to make curtains. She used $\frac{1}{3}$ of the fabric to make a long set of curtains and the rest to make 4 short sets.
- a. Find the area of the fabric she used for the long set of curtains.
- b. Find the area of the fabric she used for each of the short sets.

4. Some wire is used to make 3 rectangles: A, B, and C. Rectangle B's dimensions are $\frac{3}{5}$ cm larger than Rectangle A's dimensions, and Rectangle C's dimensions are $\frac{3}{5}$ cm larger than Rectangle B's dimensions. Rectangle A is 2 cm by $3\frac{1}{5}$ cm.
- a. What is the total area of all three rectangles?
- b. If a 40-cm coil of wire was used to form the rectangles, how much wire is left?

Name _____

Date _____

1. Draw a pair of parallel lines in each box. Then, use the parallel lines to draw a trapezoid with the following:

a. No right angles.	b. Only 1 obtuse angle.
c. 2 obtuse angles.	d. At least 1 right angle.

2. Use the trapezoids you drew to complete the tasks below.
 - a. Measure the angles of the trapezoid with your protractor, and record the measurements on the figures.
 - b. Use a marker or crayon to circle pairs of angles inside each trapezoid with a sum equal to 180° . Use a different color for each pair.
3. List the properties that are shared by all the trapezoids that you worked with today.
4. When can a quadrilateral also be called a trapezoid?
5. Follow the directions to draw one last trapezoid.
 - a. Draw a segment \overline{AB} parallel to the bottom of this page that is 5 cm long.
 - b. Draw two 55° angles with vertices at A and B so that an isosceles triangle is formed with \overline{AB} as the base of the triangle.
 - c. Label the top vertex of your triangle as C .
 - d. Use your set square to draw a line parallel to \overline{AB} that intersects both \overline{AC} and \overline{BC} .
 - e. Shade the trapezoid that you drew.

Name _____

Date _____

1. Draw a parallelogram in each box with the attributes listed.

a. No right angles.	b. At least 2 right angles.
c. Equal sides with no right angles.	d. All sides equal with at least 2 right angles.

2. Use the parallelograms you drew to complete the tasks below.
 - a. Measure the angles of the parallelogram with your protractor, and record the measurements on the figures.
 - b. Use a marker or crayon to circle pairs of angles inside each parallelogram with a sum equal to 180° . Use a different color for each pair.

3. Draw another parallelogram below.
 - a. Draw the diagonals, and measure their lengths. Record the measurements to the side of your figure.
 - b. Measure the length of each of the four segments of the diagonals from the vertices to the point of intersection of the diagonals. Color the segments that have the same length the same color. What do you notice?

4. List the properties that are shared by all of the parallelograms that you worked with today.
 - a. When can a quadrilateral also be called a parallelogram?
 - b. When can a trapezoid also be called a parallelogram?

Name _____

Date _____

1. Draw the figures in each box with the attributes listed.

a. Rhombus with no right angles	b. Rectangle with not all sides equal
c. Rhombus with 1 right angle	d. Rectangle with all sides equal

2. Use the figures you drew to complete the tasks below.

- Measure the angles of the figures with your protractor, and record the measurements on the figures.
- Use a marker or crayon to circle pairs of angles inside each figure with a sum equal to 180° . Use a different color for each pair.

Name _____

Date _____

1. Draw the figures in each box with the attributes listed. If your figure has more than one name, write it in the box.

a. Rhombus with 2 right angles	b. Kite with all sides equal
c. Kite with 4 right angles	d. Kite with 2 pairs of adjacent sides equal (The pairs are not equal to each other.)

2. Use the figures you drew to complete the tasks below.
- Measure the angles of the figures with your protractor, and record the measurements on the figures.
 - Use a marker or crayon to circle pairs of angles that are equal in measure, inside each figure. Use a different color for each pair.

3. a. List the properties shared by all of the squares that you worked with today.
- b. List the properties shared by all of the kites that you worked with today.
- c. When can a rhombus also be called a square?
- d. When can a kite also be called a square?
- e. When can a trapezoid also be called a kite?

Name _____

Date _____

1. True or false. If the statement is false, rewrite it to make it true.

	T	F
a. All trapezoids are quadrilaterals.		
b. All parallelograms are rhombuses.		
c. All squares are trapezoids.		
d. All rectangles are squares.		
e. Rectangles are always parallelograms.		
f. All parallelograms are trapezoids.		
g. All rhombuses are rectangles.		
h. Kites are never rhombuses.		
i. All squares are kites.		
j. All kites are squares.		
k. All rhombuses are squares.		

2. Fill in the blanks.

a. $ABCD$ is a trapezoid. Find the measurements listed below.

$\angle A =$ _____ $^\circ$

$\angle D =$ _____ $^\circ$

What other names does this figure have?

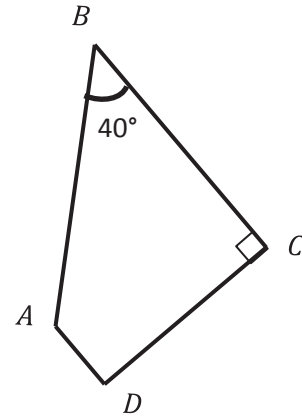

b. $RECT$ is a rectangle. Find the measurements listed below.

Line $TE =$ _____

Line $RC =$ _____

Line $CT =$ _____

$\angle ERM =$ _____ $^\circ$

$\angle CTR =$ _____ $^\circ$

What other names does this figure have?

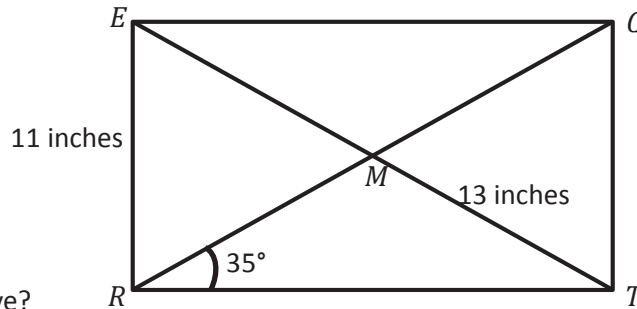

c. $PARL$ is a parallelogram. Find the measurements listed below.

Line $AL =$ _____

Line $PR =$ _____

$\angle ARL =$ _____ $^\circ$

$\angle PAR =$ _____ $^\circ$

$\angle RLP =$ _____ $^\circ$

What other names does this figure have?

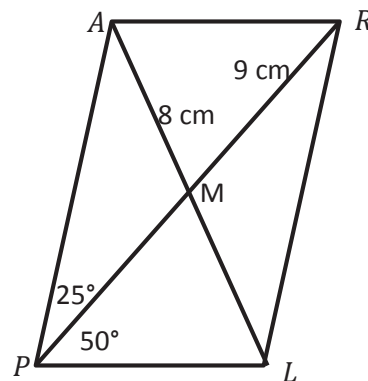

Name _____

Date _____

1. Write the number on your task card and a summary of the task in the blank. Then, draw the figure in the box. Label your figure with as many names as you can. Circle the most specific name.

Task #__ : _____ 	Task #__ : _____
Task #__ : _____ 	Task #__ : _____
Task #__ : _____ 	Task #__ : _____











Video tutorials: <http://embarc.online>
Info for parents: <http://bit.ly/pusdmath>